

PICNIC TABLE

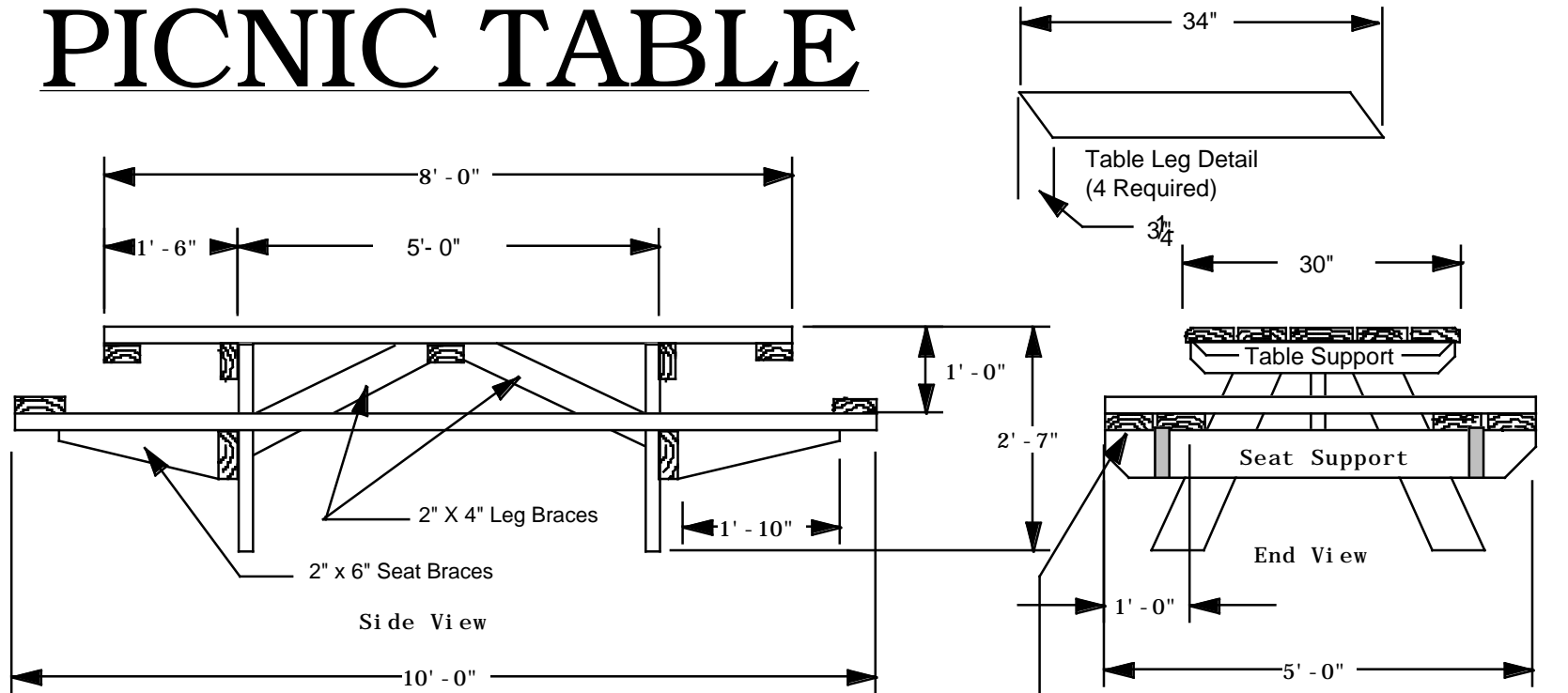

What to Buy

- Lumber** Use only treated lumber or better
- Top 4 pcs 2" X 6" X 8'
 - Top Center Bd..... 1 pcs 2" X 8" X 8'
 - Seat, Seat Brace, & Legs 3 pcs 2" X 6" X 12'
 - Seat, & Seat Support 3 pcs 2" X 6" X 10'
 - Table Support & Braces 2 pcs 2" X 4" X 10'

Hardware

Use only Galvanized hardware or better

- Carriage Bolts with Flat washer and Nuts20 pcs 3/8" X 3-1/4"
- Deck Screws60 pcs #10 X 2-1/2"
- Deck Screws50 pcs #10 X 3-1/2"

First built two A-shaped end braces to provide legs for supports for both top and seats. Legs are 2" X 6" X 34" long, with a 3-1/4" diagonal cut at each end to accommodate slant for legs (cut from a 12' board). The seat supports are two 2" X 6" 's 60" long (cut from a 12' board). Use two 2" X 4" 's 30" long for table support.

When lumber is cut, Lay pieces on ground so legs are flush with top edge of table support, 5" from the end of support. Position seat support so the seat edge is 12" below the top of the table support. Drill 3/8" holes through supports and legs. Assemble two A-shaped end braces with carriage bolt, flat washer and a nut.

If Possible surface the top boards smooth. Place the braces 5' apart on a level surface, Use the deck screws (2-1/2" long) and screw the two outside boards so they overhang the end of the table support by 1/4" and making sure that the boards are parallel. Position the rest of the boards (the 2" X 8" Board is placed as

the middle board) so the open spaces between each board will be the same and place one screw in each top board. Square of the top and place a second screw in each top board.

Cut the three table braces and place one on each end and one in the middle. Use (2-1/2") deck screws and screw these in place from underneath the top.

Measure and Cut out two leg braces and screw them in place.

Cut four 10' Seats and two 60" seats (from 12' Boards). Place each seat in place and screw (3-1/2") in place. Place the end seats in place and bolt to the other seats with carriage bolts. With the 2' pieces that is left over from the seats make the seat braces. Position them in place and use three screws (3-1/2") on top and two (3-1/2") on the ends to secure the braces.

Cut The corners of the top and seats off at a 45 deg.. Round off the edges of the top and the seat with a router. Sand any rough areas and finish as needed.

Good luck and I know you will enjoy this attractive picnic table.